



## COSMOS WALL MIXER WITH DIVERTER

### DESCRIPTION

Cosmos Wall Mixer with Diverter

### FEATURES

- Contemporary Pin Lever design
- Sturdy solid brass construction
- 140mm Wall Plate
- Taiwanese ceramic disc cartridge for smooth long life operation
- 5 year limited domestic warranty on mixer body, cartridge and chrome finish including 1 year free labour from date of purchase

## DETAILS

35mm cartridge

Part Code: A2-107

Available Finishes: Chrome

Recommended working pressure:

Min 150 – Max 500KPa

Note: If the pressure exceeds or is likely to exceed 500KPa, an approved pressure limiting device must be fitted.

Maximum hot water temperature 80°

## TECHNICAL DETAILS

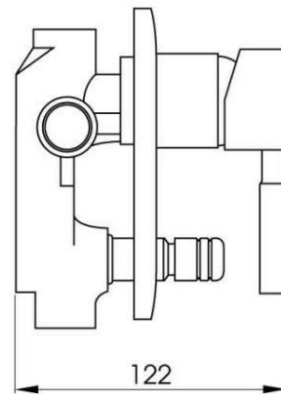
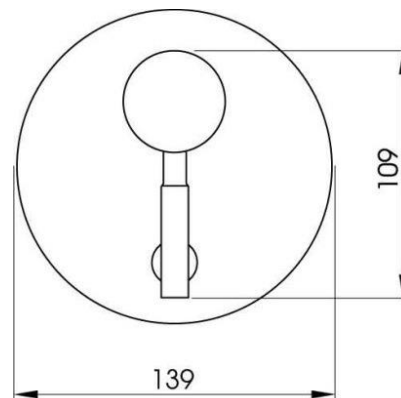

Note: Illustrations and specifications may vary from time to time