



Q4 KITCHEN SINK MIXER

DESCRIPTION

Q4 Kitchen Sink Mixer

FEATURES

- Pull-over spring design
- Dual function spray
- Solid brass construction
- Sleek design encompassing the latest up-to-date ceramic disc cartridge technology
- 10-year warranty on mixer body, cartridge and chrome finish, 5 years on coloured finishes, 1 year on all other parts. Includes 1 year free labour from date of purchase

DETAILS

35mm Cartridge

WELS 5 Star 5L/m RN: T32451

Part Code: AQK-201BN

Available Finishes: Brushed Nickel

Recommended working pressure:

Min 150 – Max 500KPa

Note: If the pressure exceeds or is likely to exceed 500KPa, an approved pressure limiting device must be fitted.

Maximum hot water temperature 60°

TECHNICAL DETAILS

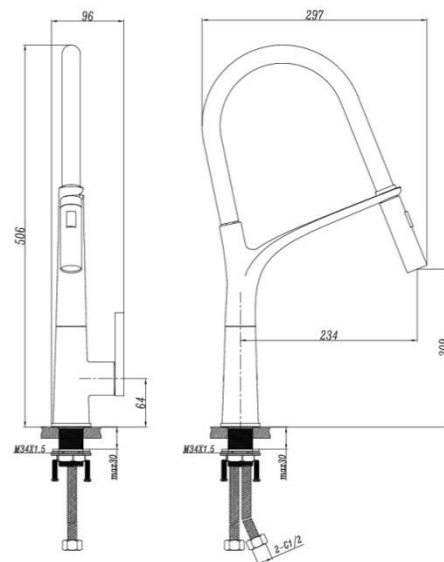

Note: Illustrations and specifications may vary from time to time