

MAG-FALCON

Waterfree Urinals



The Falcon model Flax is a vitreous china wall hung, wall outlet waterfree urinal. It requires no flush valve and water supply, and plumbs to standard drain connections.

The Flax utilizes a patented, replaceable sealed cartridge with bayonet locking features with O-rings. The cartridge is made of recyclable ABS plastic and uses a 100% biodegradable liquid sealant to control odours.

FEATURES

- Touch-free operation
- Uses no water
- Mechanical-free design
- Patented, sealed locking cartridge
- Maintenance-free cartridge
- Smooth, non-porous surfaces
- Vitreous china bowl

BENEFITS

- Improved hygiene and safety
- Reduced water and sewer costs
- No costly flush valve or sensor repairs
- Odour-free and vandal proof
- No need to replenish cartridge sealant between changes
- Minimal care and easy cleaning
- Unsurpassed durability



REPLACEMENT CARTRIDGE KITS INCLUDE

- Sealed cartridge
- Diverter shield
- Plastic installation key
- Pre-measured liquid sealant pack
- Disposal bag
- Plastic gloves
- Instruction sheet

PRODUCT CODE

WUVCCW

INSTALLATION

Shall be in accordance with the normal minimum drainline grade requirements in AS/NZS 3500

COLOUR

White

NOMINAL DIMENSIONS (W X H X D)

330 x 597 x 356 mm (13 x 23.5 x 14 inches)

APPROXIMATE WEIGHT

12.3 Kg

PRODUCT CODE

WFUFLVIT

12 month warranty

MAG-FALCON

Waterfree Urinals

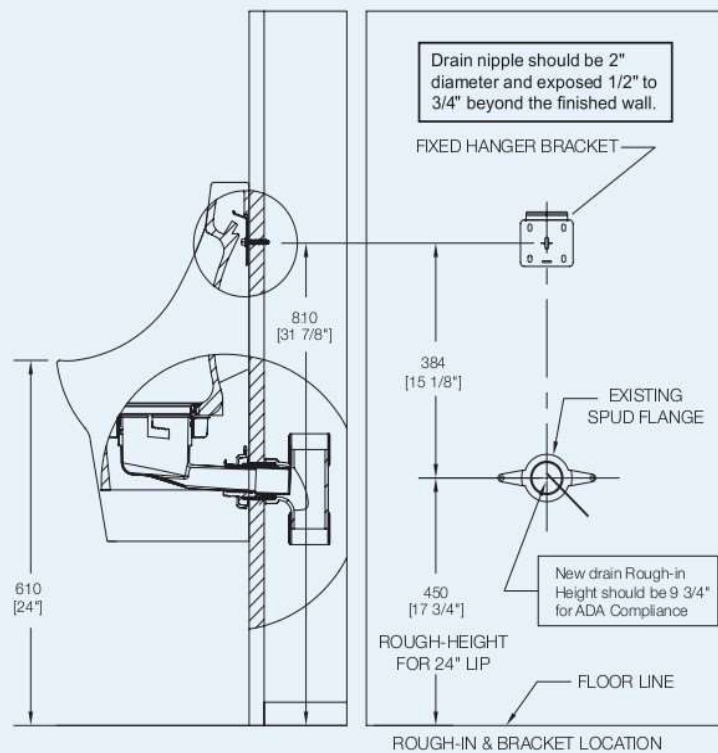
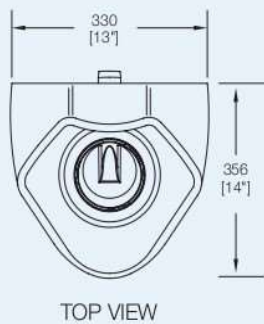
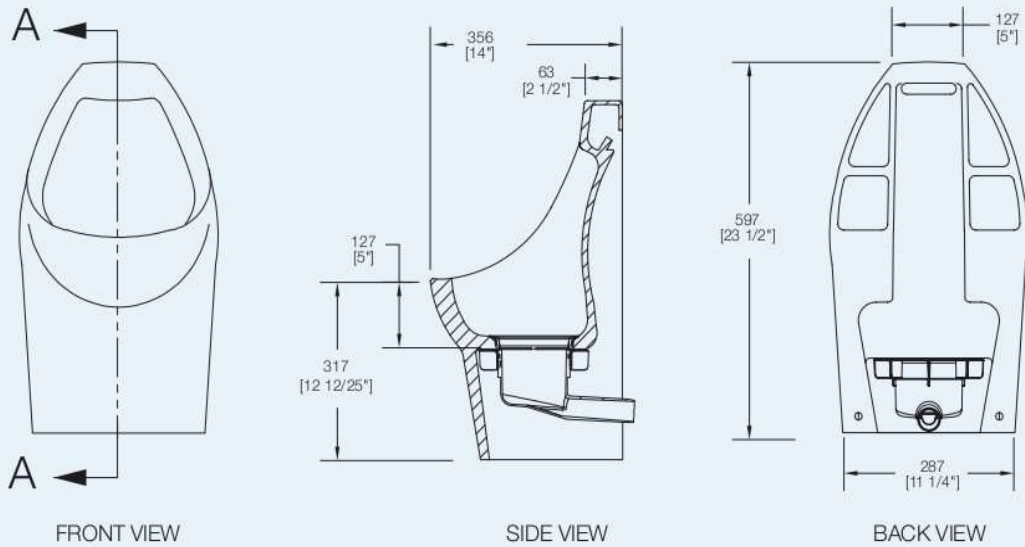

All dimensions are in millimetres and are subject to normal manufacturing variations.

CARTRIDGE KIT (available for purchase)

The patented cartridge is engineered to last about 7,000 uses in typical installations and is designed as a replaceable component when its function has been exhausted. Please see the next 2 pages for more information about our unique Velocity Cartridge technology, its benefits and performance.

MAG-FALCON

Waterfree Urinals - Velocity Cartridge

The Velocity Cartridge is the heart and soul of Falcon's Waterfree Urinals. These cartridges utilize multiple unique design patents to provide safe, long lasting, low odour performance, while saving up to an average or more than 182,000 litres of water every year. The Velocity Cartridge has 6 patent pending features to provide outstanding performance.

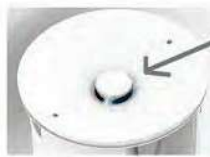

REDUCES SPLASH-BACK

An integrated diverter shield reduces splashing while helping prevent debris from entering the cartridge.

CUES YOU WHEN TO REPLACE

Our self-monitoring indicator provides a visual signal that helps you know when it is ready to be changed, making maintenance easier.

GREENER FOOTPRINT

Our Velocity cartridge boasts all of these features while using 20% less plastic than previous models.

REDUCES RESTROOM ODOURS

Our patented cartridge helps keep your restroom virtually odour-free by reducing the area where bacteria can grow.

KEEPS PIPES AND HOUSING CLEANER

Our patent-pending anti-splash pour spout utilizes speed and direction to streamline urine through your pipes and help keep your housing and drain cleaner.

RETAINS SEALANT BETTER

Our internal baffle allows the cartridge to retain its sealant barrier even under the most challenging maintenance practices.

MAG-FALCON

Waterfree Urinals - Velocity Cartridge

HOW IT WORKS

1. The cartridge begins full of liquid with a layer of proprietary biodegradable sealant that floats on the surface.
2. Waste enters the cartridge and passes through this sealant which isolates foul odours from the restroom.
3. Flowing waste is slowed by internal baffles that help retain sealant and allows the uric sediment to settle.
4. Waste flows past an internal trap and exits the cartridge leaving some of the uric sediment behind.
5. The urine accelerates as it is funnelled down to a flexible spout where it is redirected out of the housing and into the drain pipe.



ODOUR CONTROL

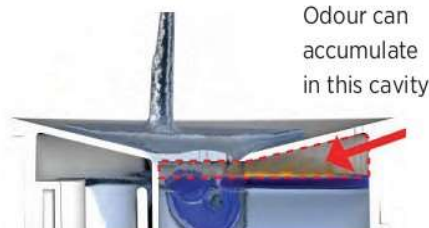

Old technology has a large surface area and cavity that can harbour bacteria and odour.



Velocity Cartridge reduces surface area and eliminates cavity to help reduce odour.

ANTI-SPLASH / BUILD UP



Competitive technology splashes, which causes build-up in housing and pipes.



Velocity Cartridge helps to eliminate splashing, which helps keep housing and pipes cleaner.